

REVISION RECORD			
REV.	CONTENT	MOD.	DATE
△	初版发行		

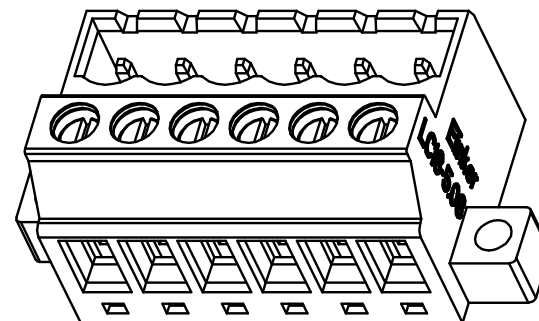
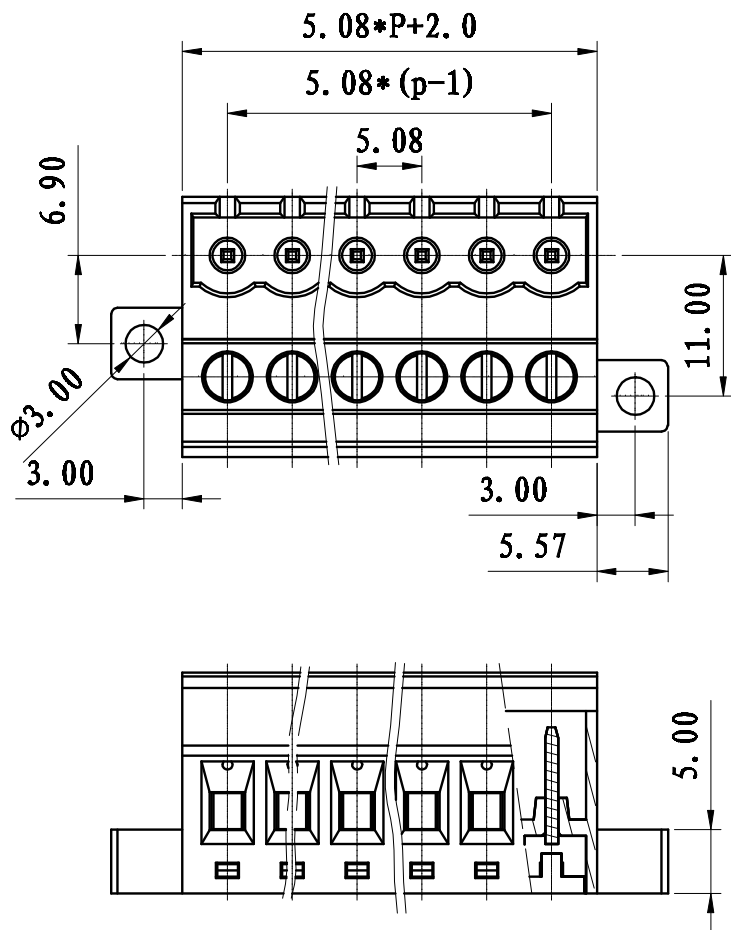

NOTES:

Pitch: 5.08mm Pole: 2-24P
 Rated Voltage: 300V
 Rated Current: 15A
 Withstand Voltage:
 AC2500V for 1 minute
 Insulation Resistance :
 500MΩ/DC500V
 Using Temperature Range :
 -40~+105°
 Wire range : 24-12 AWG
 Screw Torque Value : 0.5N.m

技术要求:

间距: 5.08mm 极数: 2-24P
 额定电压: 300V
 额定电流: 15A
 耐电压值: AC 2500V/min
 绝缘阻抗: 500MΩ
 使用条件: -40℃ ~ +105℃
 适用线规: 24-12AWG
 螺丝扭矩: 0.5 Nm

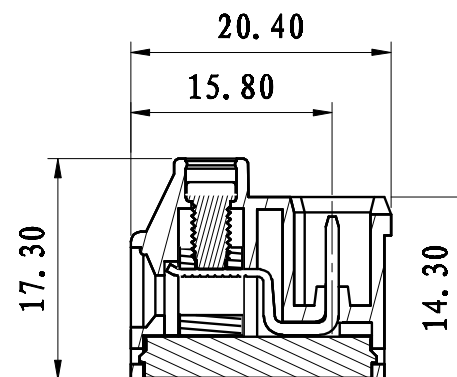

	pitch dimension			Nominal dimension					—
	over 0	over 6	over 10	over 0	over 30	over 60	over 100	over 150	
variable range	to 6	to 10	to 24	to 30	to 60	to 100	to 150		▱
Tolerance	±0.1	±0.15	±0.25	±0.2	±0.3	±0.5	±0.7	±1.0	○

5	LC18-5.08方针	1047B0001AV	P	紫铜	镀锡
4	LC1-5.08-方块	F1A0BLC5083V	P	黄铜	镀镍
3	LC1-5.08-螺丝	SPOYA305301V	P	碳钢	三价铬钝化彩锌
2	LC18-5.08盖板	1047COYXXAV	1	PA66-V0	
1	LC18-5.08主体	1047AOYXXAV	1	PA66-V0	
NO.	NAME OF PART	NO. OF PART	Q'TY	MATERIAL	NOTES
DES.	LDD	DATE 2012/05/22	UNITS mm	THIRD ANGLE PROJECTION	SHEET
CHK.		DATE	SIZE A4	⊕	1 of 1
APP.		DATE	SCALE 1:1	DWG NO. SP-2-1047002	REV: V0
上海有乐电气有限公司 Shanghai YouLe Electric CO.,LTD				TITLE	LC18-5.08-1Y-XXP-00A LC18-5.08成品